



# HERRAMIENTAS DE BRUÑIDO

## BURNISHING TOOLS



### HBB

#### + Características

- Herramienta diseñada para bruñir en torno, superficies exteriores de formas variadas
- Rodillo soportado entre rodamiento axial y radial
- Posibilidad de variar la presión de la cabeza para lograr diferentes niveles de bruñido en la pieza (Fig.1)
- Para bruñidos hasta una cara
- Utilizable sobre piezas de diferentes tipos de materiales con durezas hasta 45 HRC
- Provisto de rodillo de bruñir tipo B fabricado en HSS y templado a 62 HRC, con superficie pulida con una Ra <0,4

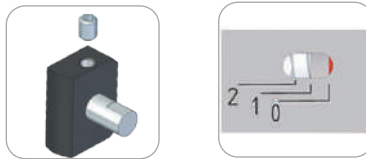
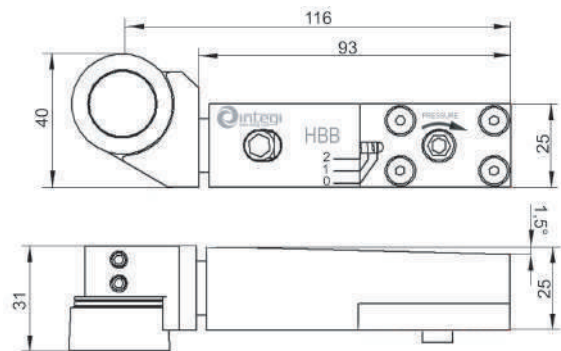

Fig. 1



#### + Features

- Tool designed for burnishing on lathes, on various profiles
- The roll is supported between axial and radial bearings
- The pressure of the head can be adjusted in order to obtain different levels of burnishing on the workpiece (Fig.1)
- Possibility of burnishing up to one face
- Usable on pieces of different types of materials with hardness of 45 HRC
- Provided with a B type burnishing roll made of HSS and tempered to 62 HRC, with a polished surface to Ra<0.4



#### + Avance Feed

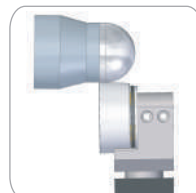
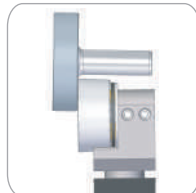
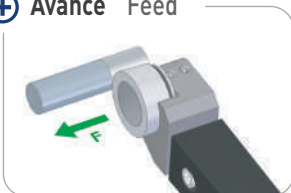

Herramienta   Tool				
Código Code	Referencia Reference	Versión Version	Rodillos Rolls	Kg
09030200	HBB 30.25 L	L	RB 30x13x20/17	0,8
09030100	HBB 30.25 R	R	RB 30x13x20/17	0,8

Repuesto   Spare Part		
Código Code	Referencia Reference	
09039902	HBB 30-EJE	
09990010	RODRAD Ø10	
09990009	RODAX Ø10	