

# HERRAMIENTAS DE BRUÑIDO BURNISHING TOOLS



## HBE

### + Características

- Herramienta diseñada para bruñir en torno, superficies exteriores de formas variadas
- Rodillo soportado entre rodamientos axiales
- Posibilidad de variar la presión de la cabeza para lograr diferentes niveles de bruñido en la pieza (Fig.1)
- Eje porta-rodillo de metal duro
- Utilizable sobre piezas de diferentes tipos de materiales con durezas hasta 45 HRC
- Provisto de rodillo de bruñir de perfil tipo E fabricado en HSS y templado a 62 HRC, con superficie pulida con una Ra <0,4

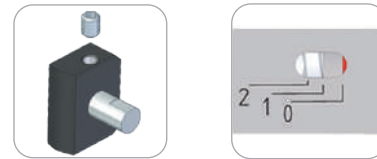
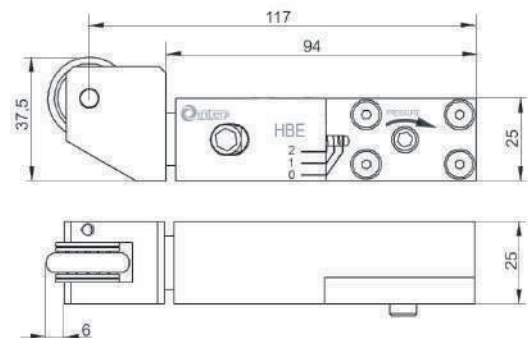

Fig. 1



### + Features

- Tool designed for burnishing on lathes, on various profiles
- The roll is supported between axial bearings
- The pressure of the head can be adjusted in order to obtain different levels of burnishing on the workpiece (Fig.1)
- Carbide pin
- Usable on pieces of different types of materials with hardness of 45 HRC
- Provided with a E type burnishing roll made of HSS and tempered to 62 HRC, with a polished surface to Ra<0.4



### + Avance Feed

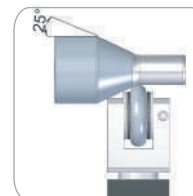
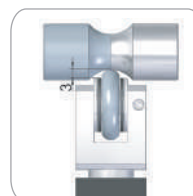
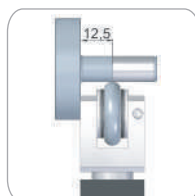

Herramienta   Tool				
Código Code	Referencia Reference	Versión Version	Rodillos Rolls	Kg
09020100	HBE 25.25	R+L	RB 25x6x6	0,8

Repuesto   Spare Part		
Código Code	Referencia Reference	
09029901	E 25.6 HM	
09990008	RODAX Ø6	