

HERRAMIENTAS DE BRUÑIDO BURNISHING TOOLS



HBM 20-B

+ Características

- Herramienta diseñada para bruñir en tornos de cabezal móvil, superficies exteriores de formas variadas
- Posibilidad de bruñir hasta una cara
- Cabeza provista de un sistema interno de resorte que regula la presión haciéndola homogénea en todas las piezas (Fig.1)
- Rodillo soportado entre rodamiento axial y radial
- Utilizable sobre piezas de diferentes tipos de materiales con durezas hasta 45 HRC
- Provisto de rodillo de bruñir de perfil tipo B fabricado en HSS y templado a 62 HRC, con superficie pulida con una Ra<0.4

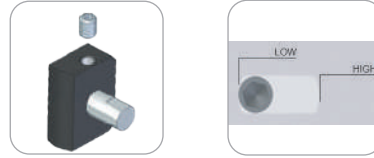
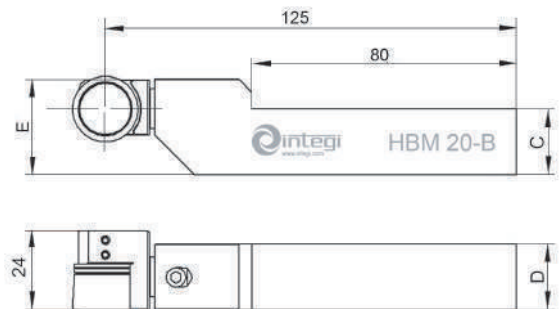

Fig. 1



+ Features

- Tool designed for burnishing on sliding head lathes, on various profiles
- Possibility of burnishing up to one face
- Head provided with an internal spring system that regulates the pressure making it homogeneous in all the workpieces (Fig.1)
- The roll is supported between axial and radial bearing
- Usable on pieces of different types of materials with hardness of 45 HRC
- Provided with a B type burnishing roll made of HSS and tempered to 62 HRC, with a polished surface to Ra<0.4



+ Avance Feed

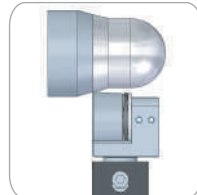

Herramienta Tool							
Código Code	Referencia Reference	Versión Version	Rodillos Rolls	C	D	E	Kg
09050101	HBM 20.12 R-B	R	RB 20x11x16/13	12	12	21	0,3
09050103	HBM 20.12 L-B	L	RB 20x11x16/13	12	12	21	0,3
09050201	HBM 20.16 R-B	R	RB 20x11x16/13	16	16	25	0,4
09050203	HBM 20.16 L-B	L	RB 20x11x16/13	16	16	25	0,4
09050301	HBM 20.20 R-B	R	RB 20x11x16/13	20	20	29	0,5
09050302	HBM 20.20 L-B	L	RB 20x11x16/13	20	20	29	0,5

Repuesto Spare Part		
Código Code	Referencia Reference	
09990020	HB 20-EJE-CABEZA B	
09990008	RODAX Ø6	
09990019	RODRAD Ø6	