



HERRAMIENTAS DE BRUÑIDO BURNISHING TOOLS



HBED

+ Características

- Herramienta diseñada para bruñir en tornos de cabezal móvil, superficies exteriores de formas variadas
- Cabeza provista de un sistema interno de resorte que regula la presión haciéndola homogénea en todas las piezas (Fig.1)
- Utilizable sobre piezas de diferentes tipos de materiales con durezas de hasta 63 HRC
- Posibilidad de colocar la punta de diamante en diferentes posiciones para prolongar la vida del útil

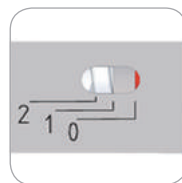

(Fig.1)



+ Features

- Tool designed for burnishing external diameters of various shapes on sliding head lathes
- The head is equipped with an internal spring system to regulate the pressure of the diamond tip, making it homogeneous on all parts (Fig.1)
- Can be used on workpieces made of different types of materials with hardness up to 63 HRC
- Possibility of placing the diamond tip in different positions to extend the life of the tool

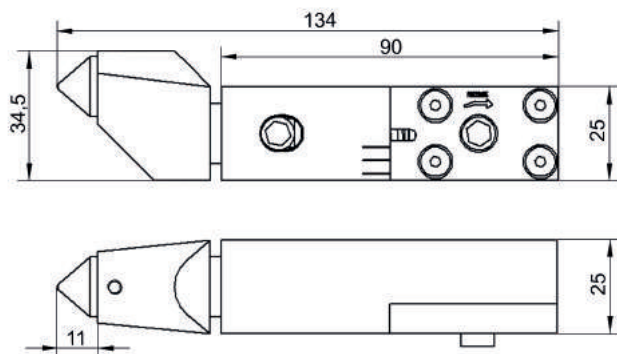

+ Avance Feed

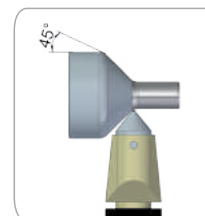
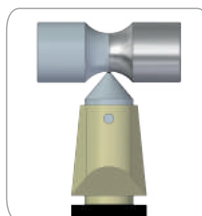
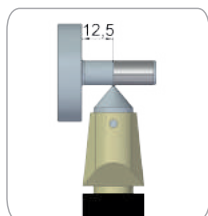
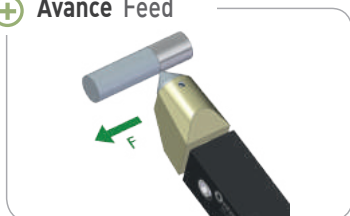

Herramienta Tool						
Código Code	Referencia Reference	Versión Version	Diamante Diamond	C	D	Kg
09150100	HBED 25	R+L	DT 16	25	25	0,4

Punta de diamante Diamond tip	
Código Referencia	Referencia Reference
10010204	DT 16-R0.4
10010208	DT 16-R0.8
10010210	DT 16-R1.0
10010220	DT 16-R2.0

