



# MOLETEADORES POR CORTE CUT-KNURLING TOOLS



## MF 14

### + Características

- Recomendado para moleteados tipo RGE
- Ajuste de las moletas según diámetro a moletear mediante escala graduada (Fig. 2)
- Cabeza basculante para el alineamiento de las moletas (Fig. 1)
- Ejes de HSS+TIN
- Ajuste del ángulo de ataque mediante tornillos integrados en el mango

### + Features

- Recommended for RGE type knurling
- Easy setting to the workpiece diameter by means of a graduated scale (Fig. 2)
- Pivoting head for knurls self-centering (Fig. 1)
- HSS+TIN bushing
- Adjustment of tool clearance angle by threaded studs integrated in the shank

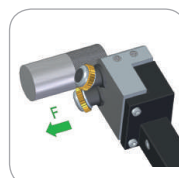
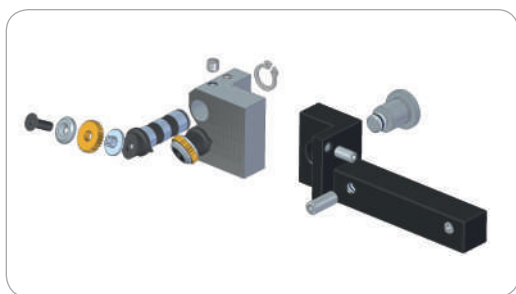

(Fig. 1)

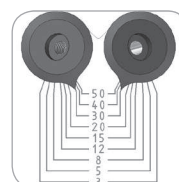

(Fig. 2)

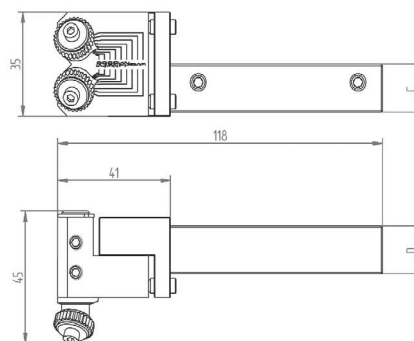

### + Avance Feed

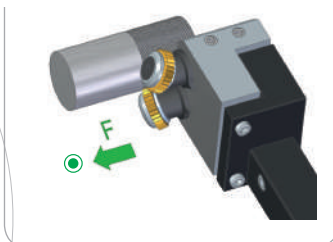

### + Formas de moleteados realizables Feasible knurling forms

	R RGE 30°	R RGE 45°
Tipo de moleteado Knurling form		
Con moleta tipo With knurl type	AA + AA	BL15° + BR15°
Avances permitidos Allowed feeds	F	F

### R Moleteados recomendados | Recommended knurling

Herramienta   Tool							
Código Code	Referencia Reference	Versión Version	Capacidad Capacity	Moleta Knurl	C	D	Kg Kg
01100900	MF14.53.12 R	R	∅ 3 ÷ 50	14.5x3x5	12	16	0.5
01101000	MF 14.53.12 L	L	∅ 3 ÷ 50	14.5x3x5	12	16	0.5
01100100	MF 14.53.14 R	R	∅ 3 ÷ 50	14.5x3x5	14	16	0.5
01100200	MF 14.53.14 L	L	∅ 3 ÷ 50	14.5x3x5	14	16	0.5
01100300	MF 14.53.16 R	R	∅ 3 ÷ 50	14.5x3x5	16	16	0.5
01100400	MF 14.53.16 L	L	∅ 3 ÷ 50	14.5x3x5	16	16	0.5

Repuesto   Spare Part	
Código Code	Referencia Reference
01985600	EAT 14.53

