



MOLETEADORES POR CORTE CUT-KNURLING TOOLS



MF1 14

+ Características

- Recomendado para moleteados tipo RGE
- Ajuste de las moletas según diámetro a moletear mediante escala graduada (Fig. 2)
- Doble posición del mango para trabajar a derechas o izquierdas (Fig. 1)
- Ejes de HSS+TIN
- Ajuste del ángulo de ataque mediante tornillos integrados en el mango

+ Features

- Recommended for RGE type knurling
- Easy setting to the workpiece diameter by means of a graduated scale (Fig. 2)
- Tool with reversible shank able to fit on left-hand or right-hand lathes (Fig. 1)
- HSS+TIN bushing
- Adjustment of tool clearance angle by threaded studs integrated in the shank

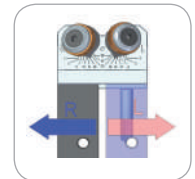
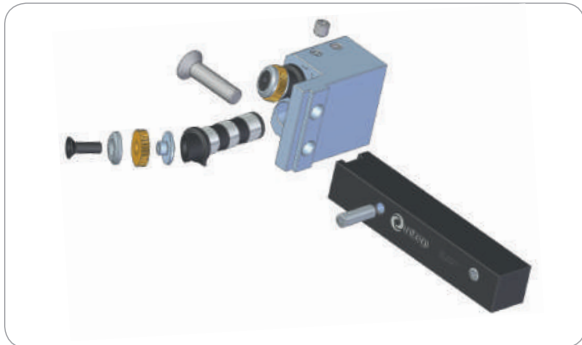

(Fig. 1)

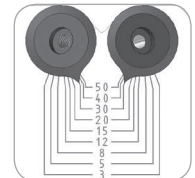

(Fig. 2)

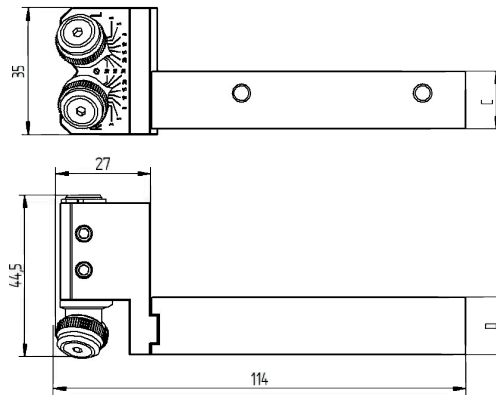

+ Avance Feed

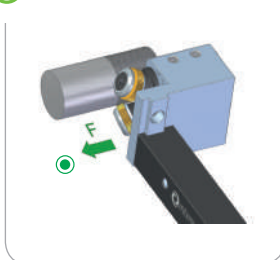

+ Formas de moleteados realizables Feasible knurling forms

	R RGE 30°	R RGE 45°
Tipo de moleteado Knurling form		
Con moleta tipo With knurl type	AA + AA	BL15° + BR15°
Avances permitidos Allowed feeds	F	F

R Moleteados recomendados | Recommended knurling

Herramienta Tool							
Código Code	Referencia Reference	Versión Version	Capacidad Capacity	Moleta Knurl	C	D	Kg Kg
01250100	MF1 14.53.12	R+L	∅ 3 ÷ 50	14.5x3x5	12	14	0.5
01250200	MF1 14.53.14	R+L	∅ 3 ÷ 50	14.5x3x5	14	14	0.5
01250300	MF1 14.53.16	R+L	∅ 3 ÷ 50	14.5x3x5	16	16	0.5

Repuesto Spare Part	
Código Code	Referencia Reference
01985600	EAT 14.53

